

DUPLEX type mills manufactured by **GRUBER HERMANOS, S. A.**, are characterized by a **very rugged** and experimented **design**, which bestows them with very low maintenance expenses and an **almost non-existent quantity of breakdowns**, so that a **very long operating life cycle** can be achieved .

This category of mills is indicated to reduce materials to particle sizes greater **than 500 microns** and a low quantity of fines.

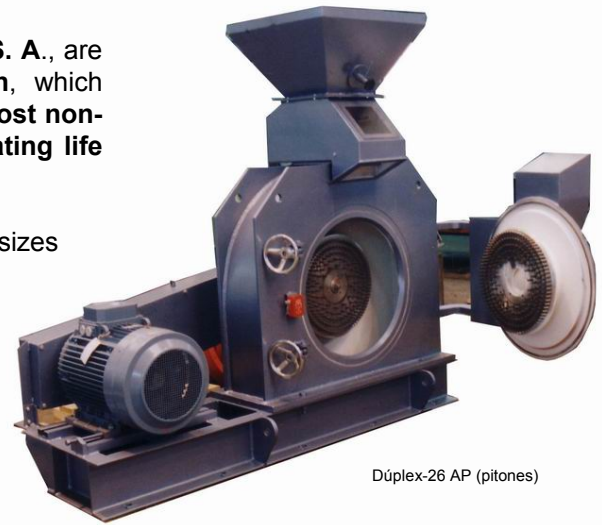

Dúplex-26 AP (pitones)

usual executions:

- on frame (according to sketch)
- on ground product collector with decompression sleeves
- with hopper for direct bagging
- on frame for pneumatic conveyors
- on frame for classification equipments
- For further versions, please contact us.

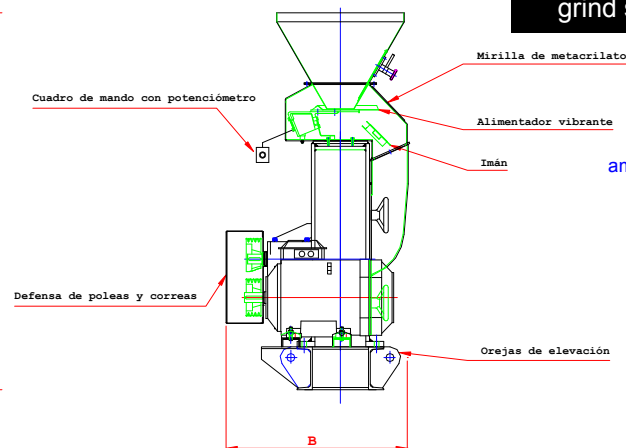
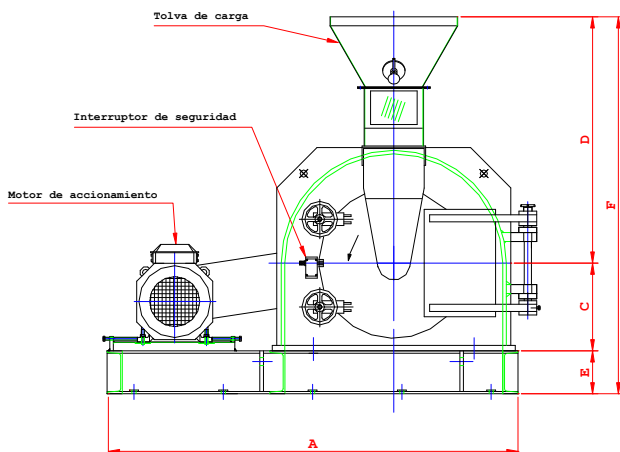
DUPLEX mills can grind successfully:

agar
 alabaster
 alumina
 ammonium nitrate
 ammonium persulphate
 calcium carbonate
 cereal
 cinamon
 coal
 cocoa beans
 coffee beans
 detergent
 dried milk
 flour
 graphite
 gum arabic
 jelly
 lead oxide
 liquorice
 magnesium
 natural & synthetic resins
 pepper
 plaster
 PVC
 soap
 soda
 sugar
 sulphur
 talc
 thyme
 urea
 vanilla
 whitening
 ... and more.

TIPO	CLASE	elementos de molienda	rpm	KW (HP)	A	B	C	D	E	F
Dúplex 21		estrella moledora	6 000	1,1 (1,5)	800	400	125	560	80	765
Dúplex 22	AM AP	martillos pitones	4 500 8 000	4 (5,5)	900	550	190	690	100	980
Dúplex 23	AM AP	martillos pitones	4 000 8 000	7,5 (10)	1 200	860	255	805	120	1 180
Dúplex 24	AM AME AP	martillos batidores pitones	3 000 3 200 6 500	18,5 (25) 22 (30) 18,5 (25)	1 600	790	380	1 100	140	1 620
Dúplex 25	AM AME	martillos batidores	2 800 2 600	30 (40)	2 000	950	490	1 385	180	2 055
Dúplex 26	AP MICRO	pitones	6 000 9 000	37 (50) 22/37 (30/50)	2 000 2 400	950 1 200	490 490	1 385 1 350	180 240	2 055 2 100
Dúplex 29	AM AME	martillos batidores		75 (100)	2 900	1 000	500	1 415	300	2 500
Dúplex 30	AP	pitones	4 400	75 (100)	2 900	1 000	500	1 415	300	2 500

*Aprox. Meassures in milimeters

GRUBER HERMANOS, S. A.

Workshops and Offices located in:
 Zumalacárregui, 30 - 48 903 Barakaldo - Vizcaya - SPAIN
 Teléfono +34 94 499 13 00
 Fax: +34 94 499 10 90
gruber@gruberhermanos.com
www.gruberhermanos.com

DUPLEX mill series are manufactured with three different grinding systems, PINS, STRIKERS and HAMMERS, always chosen in accordance to the treated material, the size of the entering fragments and the final particle size to be obtained.

Our technical department is at the customers disposal and will provide **the best solution for the specific problems that each different product or manufacturing process may pose.**

Operation Rules

The material introduced into the Mill is forced to go through the grinding elements that rotate at high speed producing an impact reduction. This reduction will be greater, the more steps are arranged in the path of the product.

Pins Mills have 2 plates, one fixed and one mobile, with several rows of pins arrange circularly. These are concentric rows, so the introduced material into the Mill must go through them while rotating at high speed.

In the case of Hammer Mills, after the first impact reduction a second one is produced by shearing or cutting, forcing the product through a grid with hammers arrange perimetally.

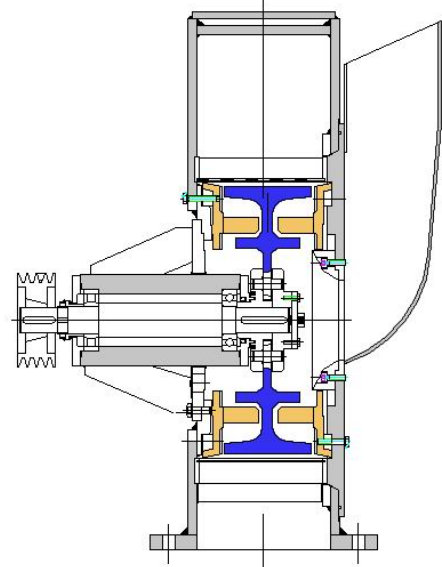

DUPLEX mill type AM, fitted with hammers – cutaway view.

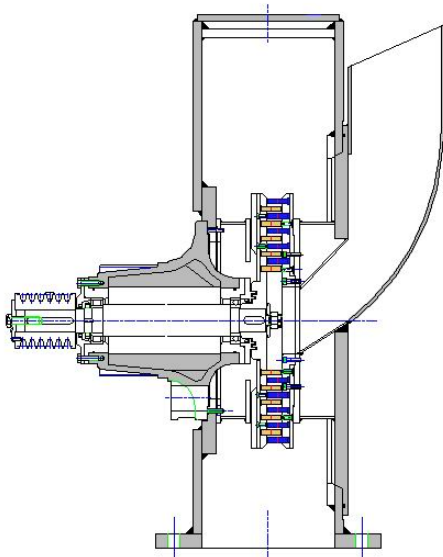

DUPLEX mill type AP, fitted with pins, cutaway view.

A special case is the **DUPLEX-26 MICRO**, where the material grinding becomes a micronization.

In this mill the two pins plates rotate in opposite direction to increase the difference in relative rotational speed. The impact generated in the material is proportional to this difference in speed.

By this way is achieved a further reduction size than classical pins mill.

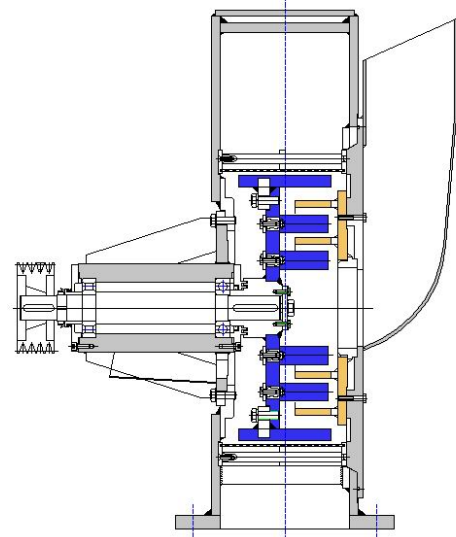

DUPLEX mill type AME, fitted with strikers, cutaway view.

If you want to know more about machinery/equipments manufactured by GRUBER HERMANOS, do not hesitate to contact our technical department. They are at your disposal and will provide a **solution** tailored to your needs.

GRUBER HERMANOS, S. A.

Workshops and Offices located in:
Zumalacárregui, 30 - 48 903 Barakaldo - Vizcaya - SPAIN
Teléfono +34 94 499 13 00
Fax: +34 94 499 10 90
gruber@gruberhermanos.com
www.gruberhermanos.com