

Biconical mixer manufactured **GRUBER HERMANOS, S. A.** are suitable for solids and granulated products homogenization processes in which an intimate mixer and ease in cleaning processes is seek.

This type of mixers are specially indicated in the processes of mixing and homogenization of the **chemical, pharmaceutical and plastic industries.**

The **dimensions** of the mixer body, its **shape** and **constructive manner**, makes emptying **completely** the mixer after each mixture and that no material remains inside. Ensuring **there are no unwanted deposits of material on the inside of the machine.**

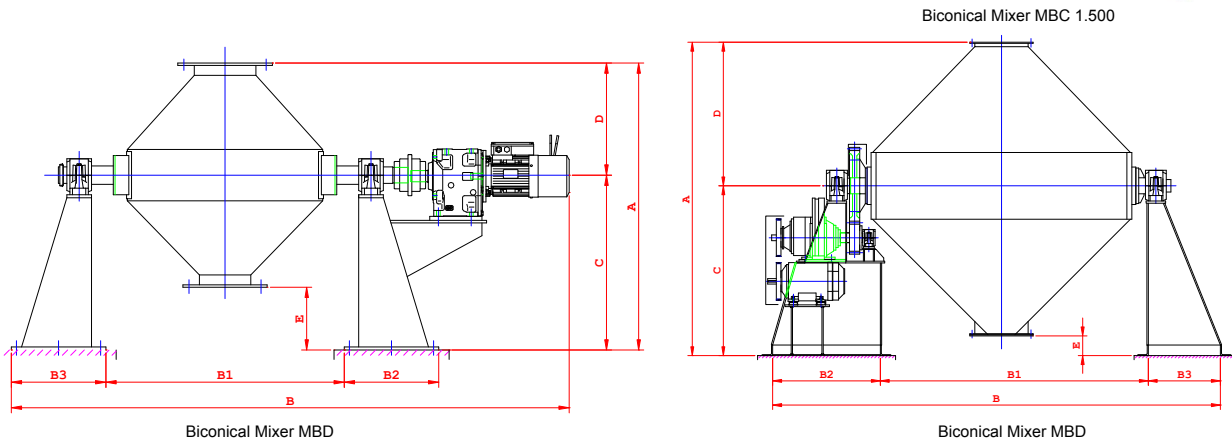
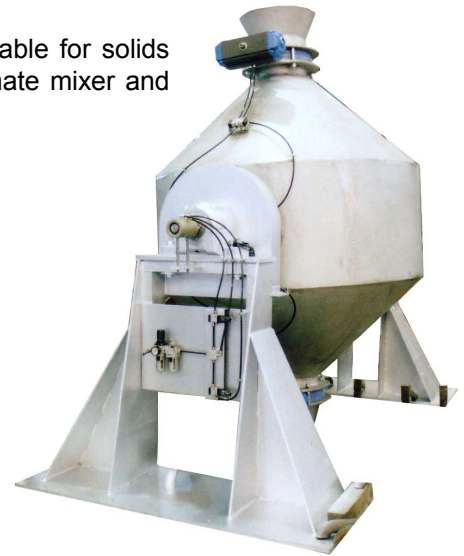

| TIPO              | CAPACIDAD (litros) |        | KW (HP)   | rpm | A     | B     | B1    | B2    | B3    | C     | D     | E   |
|-------------------|--------------------|--------|-----------|-----|-------|-------|-------|-------|-------|-------|-------|-----|
|                   | ÚTIL               | TOTAL  |           |     |       |       |       |       |       |       |       |     |
| <b>MBD 200</b>    | 165                | 200    | 1,5 (2)   | 22  | 1 450 | 1 900 | 950   | 250   | 650   | 950   | 500   | 500 |
| <b>MBD 400</b>    | 260                | 400    | 2,2 (3)   | 22  | 1 600 | 2 150 | 1 075 | 250   | 725   | 950   | 650   | 300 |
| <b>MBD 600</b>    | 390                | 600    | 3 (4)     | 20  | 1 800 | 2 470 | 1 200 | 300   | 970   | 1 000 | 800   | 300 |
| <b>MBD 800</b>    | 520                | 800    | 4 (5,5)   | 20  | 1 950 | 2 800 | 1 480 | 300   | 1 020 | 1 100 | 850   | 300 |
| <b>MBD 1.000</b>  | 650                | 1 000  | 4 (5,5)   | 20  | 2 100 | 3 000 | 1 600 | 400   | 1 000 | 1 200 | 900   | 300 |
| <b>MBC 1.500</b>  | 975                | 1 500  | 5,5 (7,5) | 18  | 2 200 | 3 300 | 1 900 | 400   | 1 000 | 1 200 | 1 000 | 200 |
| <b>MBC 2.000</b>  | 1 300              | 2 000  | 5,5 (7,5) | 18  | 2 300 | 3 500 | 2 050 | 400   | 1 050 | 1 250 | 1 000 | 200 |
| <b>MBC 3.000</b>  | 1 950              | 3 000  | 7,5 (10)  | 16  | 2 400 | 4 000 | 2 500 | 500   | 1 000 | 1 400 | 1 000 | 200 |
| <b>MBC 5.000</b>  | 3 300              | 5 000  | 11 (15)   | 14  | 2 800 | 4 200 | 2 600 | 500   | 1 100 | 1 700 | 1 100 | 200 |
| <b>MBC 8.000</b>  | 5 200              | 8 000  | 18,5 (25) | 10  | 3 400 | 4 800 | 3 000 | 600   | 1 200 | 2 000 | 1 400 | 300 |
| <b>MBC 10.000</b> | 6 500              | 10 000 | 30 (40)   | 8   | 3 800 | 5 200 | 3 200 | 700   | 1 300 | 2 200 | 1 600 | 350 |
| <b>MBC 12.000</b> | 8 000              | 12 000 | 45 (60)   | 7   | 3 540 | 5 290 | 2 790 | 1 050 | 1 450 | 1 910 | 1 600 | 200 |

\*Medidas aproximadas en milímetros, sujetas a confirmación

\*\* Para otras capacidades, consultar

**GRUBER HERMANOS, S. A.**

Workshops and Offices located in:  
Zumalacárregui, 30 - 48 903 Barakaldo - Vizcaya - SPAIN

Teléfono +34 94 499 13 00

Fax: +34 94 499 10 90

[gruber@gruberhermanos.com](mailto:gruber@gruberhermanos.com)

[www.gruberhermanos.com](http://www.gruberhermanos.com)

MBD 200/12 000-5 es

V.05.04

### Operating principles

The product is loaded at the top of the machine, while the machine is stopped. Once the loading is finished drum of the machine starts spinning.

By effect of the centrifugal force and the gravity, the materials are mixed more intimate, the longer time in the machine and rotation speed.

Once the blend, the machine stops in vertical position and discharge occurs at the exit.

By modifying the rotation speed of the machine can achieve different degrees of homogenization.



Biconical Mixer MBC 10.000, with 10.000 l of capacity.



Biconical Mixers MBD 500, in stainless steel

This type of mixer is designed for discontinuous processes, controlled either automatically or manually.

The mechanical elements are designed for stable operation without adjustments and a long maintenance free life .

### Special executions:

- ✓ Special polished both inside and outside the body
- ✓ Reinforced construction to work under pressure or vacuum
- ✓ Spray nozzles for addition of liquids ( solvents, perfums, grease,...)
- ✓ Heating and cooling by liquid circulation jacket or steam
- ✓ Special features on drawing or specification

**GRUBER HERMANOS, S. A.** Technical-Sales Department is at your disposal to answer all your questions or queries you may have about the processes of mixing, providing your experience to find the solution that fits your needs.

### GRUBER HERMANOS, S. A.

Workshops and Offices located in::  
Zumalacárregui, 30 - 48 903 Barakaldo - Vizcaya - SPAIN  
Teléfono +34 94 499 13 00  
Fax: +34 94 499 10 90  
[gruber@gruberhermanos.com](mailto:gruber@gruberhermanos.com)  
[www.gruberhermanos.com](http://www.gruberhermanos.com)

MBD 200/12 000-5 es  
V.05.04